

# ELECTRONIC VISIONS, INC.

## PC-LOG 2

### PC-LOG 2

PC-LOG 2 is an Electronic Visions, Inc. product which replaces serial terminals and/or logging devices with an intelligent micro-computer interface. Data normally lost on conventional terminals is now captured and recorded to disk or WORM -based log files. The voluminous amounts of paper generated by hardcopy logging devices is eliminated. PC-LOG allows rapid location of important messages by providing review and search capabilities. Archiving is supported through disk copies and serial transfers of log files.

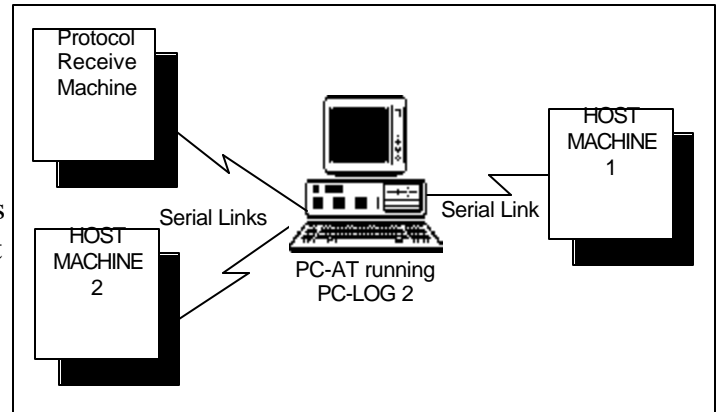

Figure 1, Typical PC-LOG 2 Connection

### FEATURES

- » Connect to two different host systems simultaneously
- » Log each host's messages to separate, local disk files, with optionally different drives and directories
- » Review and search any log file while logging continues (including the ACTIVE log files)
- » Integrated file management, including Copy, Erase, and Protocol Transfer (XModem, YModem, Kermit, etc.)
- » Context sensitive help
- » Keeps either reusable weekly log files (SUN.LG1 through SAT.LG1) or daily log files (90JUL17.LG1)
- » Data rates of up to 19.2K baud with or without flow control
- » Software (XON/XOFF) or hardware flow control
- » Blank line and trailing blank suppression
- » Local echo supported
- » Change local time and date
- » Automatically uses text display modes up to 132 columns by 60 lines

### CONFIGURATION

- » Each host session is separately configurable
- » Serial communication parameters
- » Logging behavior
- » File transfer communication parameters
- » User interface behavior
- » Shift lock states
- » Screen colors

### REQUIREMENTS

- » IBM® PC-AT or 100% Compatible with a fixed disk drive and 1 Serial port (2 ports for multiple host sessions or protocol transfers)
- » DOS 3.x (DOS 4.x if log files are to exceed 32mb in size)

### Electronic Visions, Inc.

1555 Magnolia St NE  
 Palm Bay, FL 32905  
 Voice: (321) 632-7530  
<http://www.e-visions.com>